

Manufacturing of Mechanical components using CNC turning & milling (MECH)

<p>Course Learning Objectives</p>	<ul style="list-style-type: none"> ● Exploring the concept of CNC programming, operations and making applications on CNC turning /milling machines. ● Gaining Advanced knowledge of CNC machining process and hands-on experience to program and machine the component. ● Applying the concepts of machining and equipment handling with Program in CNC Turning /Milling machines. ● Comprehending the advantages and application of CNC turning /milling machines in the manufacturing industry with industrial component drawings. ● Hands-on experience in component manufacturing as per industrial practice.
<p>Course Outcomes</p>	<ul style="list-style-type: none"> ● Explore the modern manufacturing technologies. ● Create the programs for industrial components produced by CNC machines. ● Analyze the Cutting process parameter selection, tools and path planning. ● Exhibit industrial skills in the field of automotive manufacturing. ● Implement multiple skill sets under the domain of manufacturing. ● Implement the industrial measuring practice and examine functionality and comparison of final product as per specification.

Course Duration: 45 Hours

UNIT I CNC technology and CNC programming

CNC programming Introduction and demonstration of line programs - CNC programming on lathe & milling machine - CNC programming for lathe and milling machines using different machining cycles - Procedures Associated with part programming, Cutting process parameter selection, Process planning issues and path planning - G & M Codes, Interpolations, Canned Cycles and Subprograms.

UNIT II Programming generation and application in CNC Simulator

Functions and Identification of different parts of CNC lathe including data input - Functions and Identification of different parts of CNC mill including data input -Tool compensations Exposure for programming and simulation in Fanuc control - CNC programming on lathe & milling machine for different operations in simulator - Practice on CNC controller using on-screen simulation for generating different profile.

UNIT III Programming and Operations in CNC Turning

Plan and optimize programs for CNC turning operations - Calculate parameters like speed, feed etc- set a reference for the various operations - Prepare operation and operation sequence for the lathe operations like turning, grooving etc - Prepare & set CNC lathe operations and test run programmed - Execute program and inspect simple geometrical forms / standard parts - Use of various PPE's on CNC lathe machine.

UNIT IV Programming and Operations in CNC Milling

Plan and optimize programs for CNC Milling operations - Calculate parameters like speed feed, depth of cut etc - Set a reference for the various operations. - Various methods of work process like edge finding, block center etc - Prepare operation and operation sequence for the milling operations like face milling, End milling, Drilling, etc -Prepare & set CNC Milling operations and test run programmed - Execute program and inspect simple geometrical forms / standard parts - Use of various PPE's on CNC milling machine.

2) PART NAME - COCK BODY

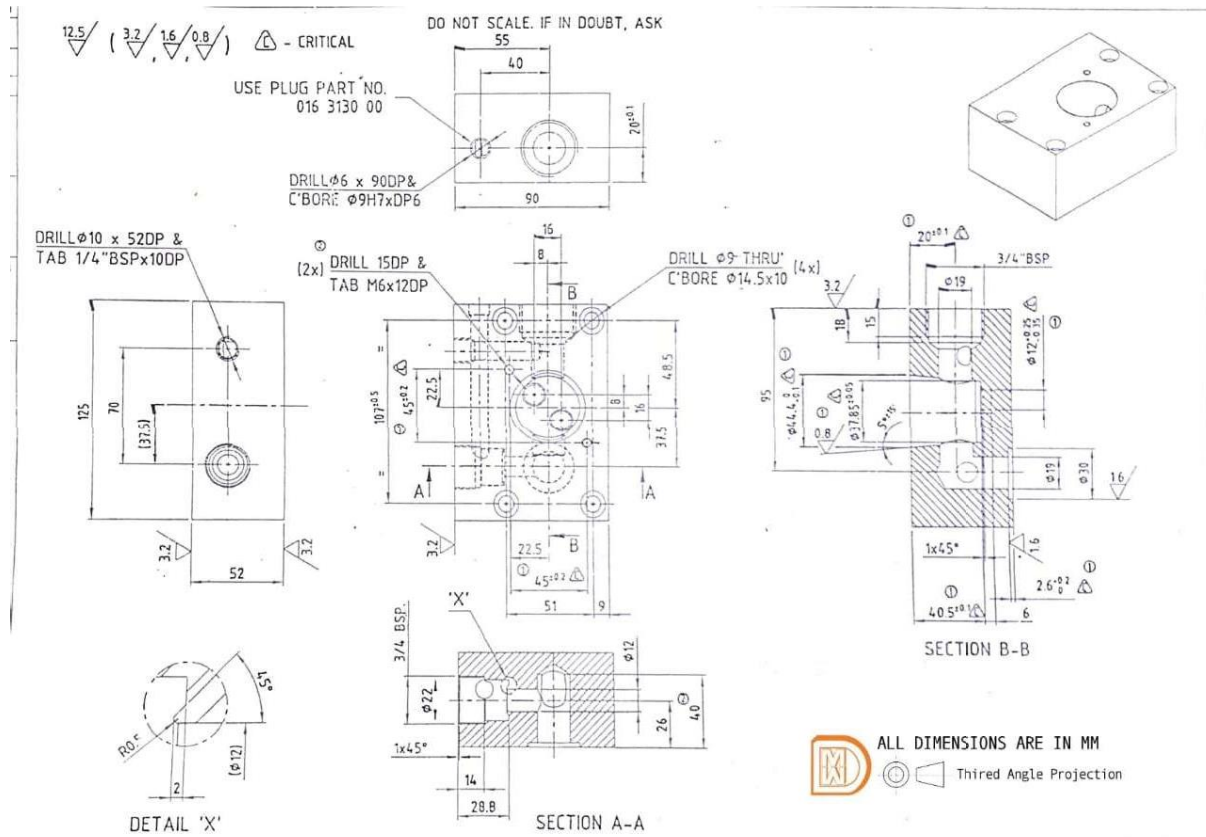

TASK:

1. Production drawing reading
2. Program writing
3. Simulation and analysis
4. Selection of tools and work holding devices
5. Machined component inspection

3) PART NAME –BODY ADAPTER QUICK EXHAUST

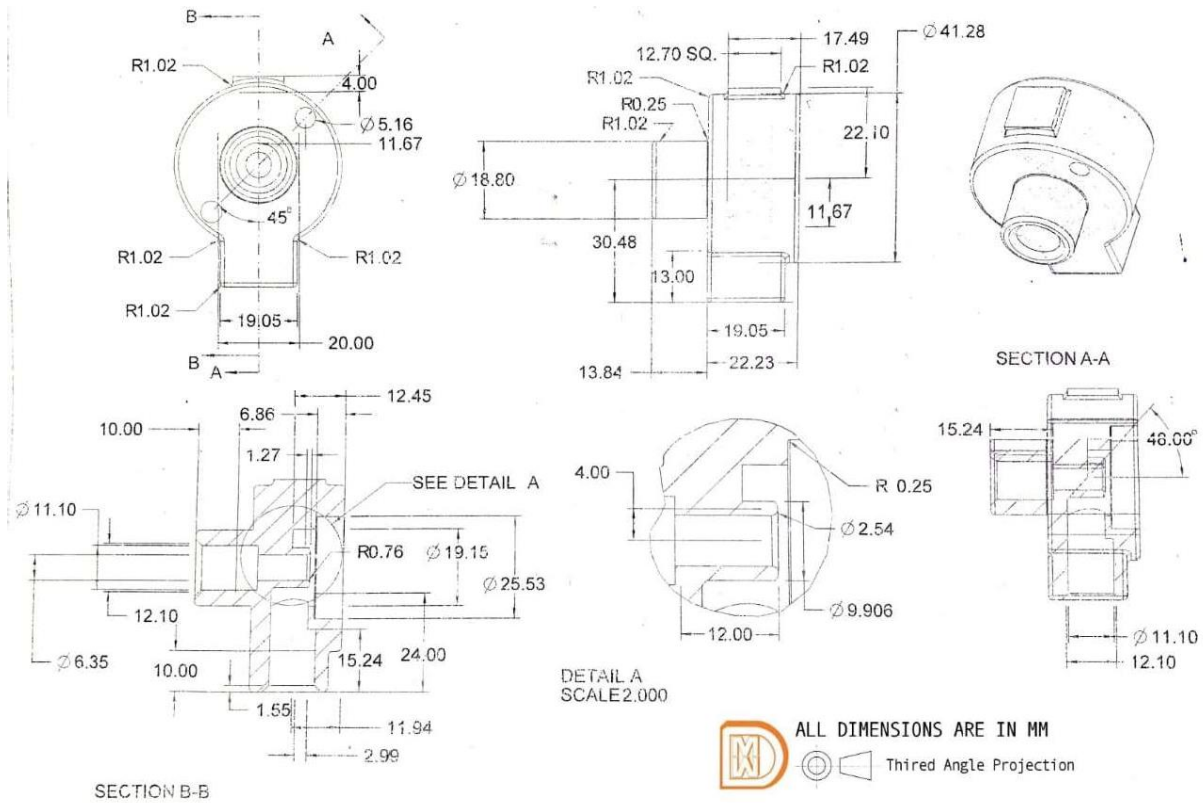

TASK:

1. Production drawing reading
2. Program writing
3. Simulation and analysis
4. Selection of tools and work holding devices
5. Machined component inspection

4) PART NAME - DISTRIBUTOR BODY

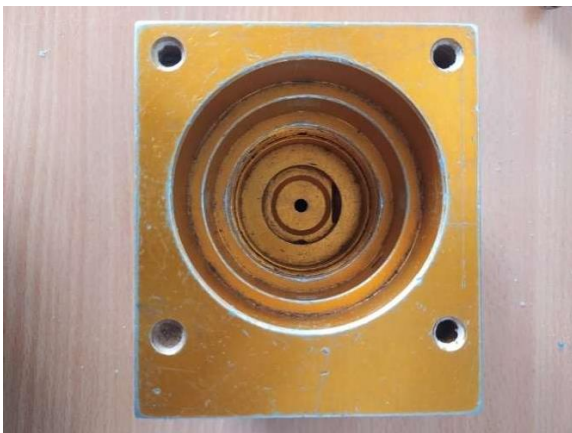
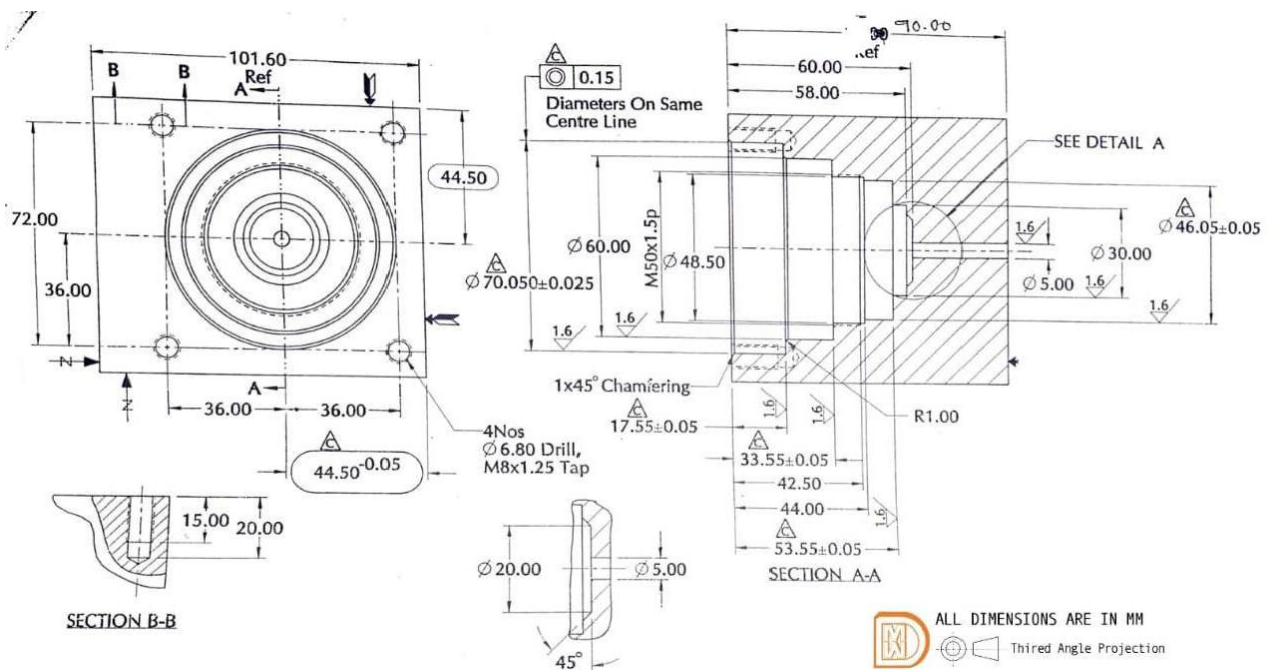

TASK:

1. Production drawing reading
2. Program writing
3. Simulation and analysis
4. Selection of tools and work holding devices
5. Machined component inspection

5) PART NAME - BODY PIPE THD SERIES

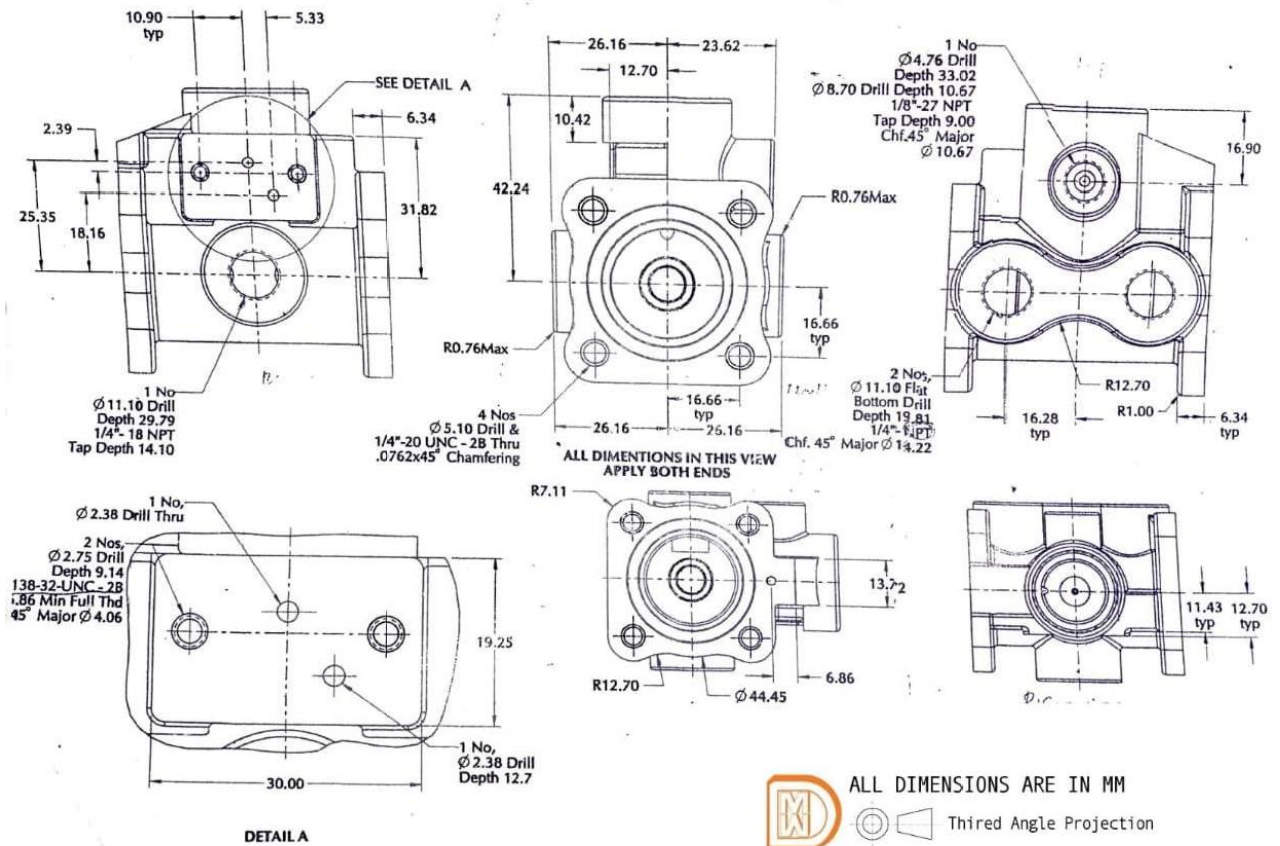

TASK:

1. Production drawing reading
2. Program writing
3. Simulation and analysis
4. Selection of tools and work holding devices
5. Machined component inspection

13

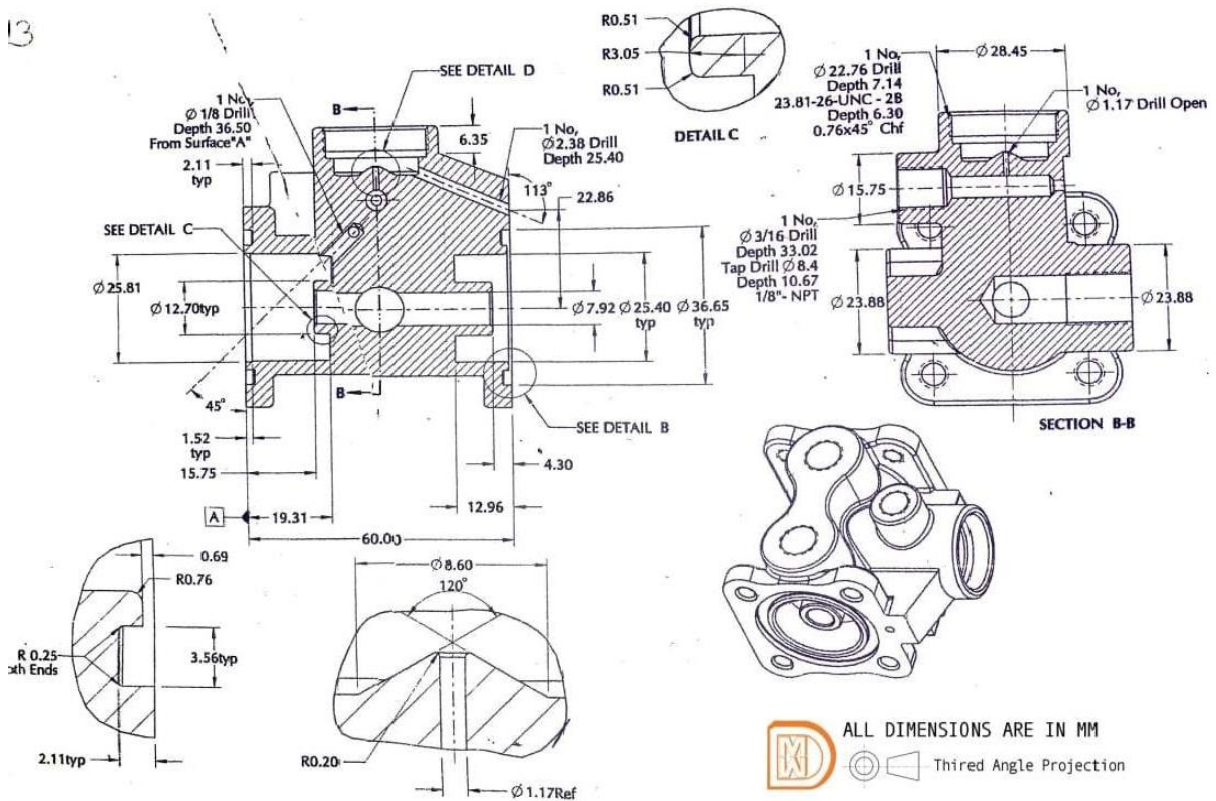

TASK:

1. Production drawing reading
2. Program writing
3. Simulation and analysis
4. Selection of tools and work holding devices
5. Machined component inspection

6) PART NAME - MANIFOLD

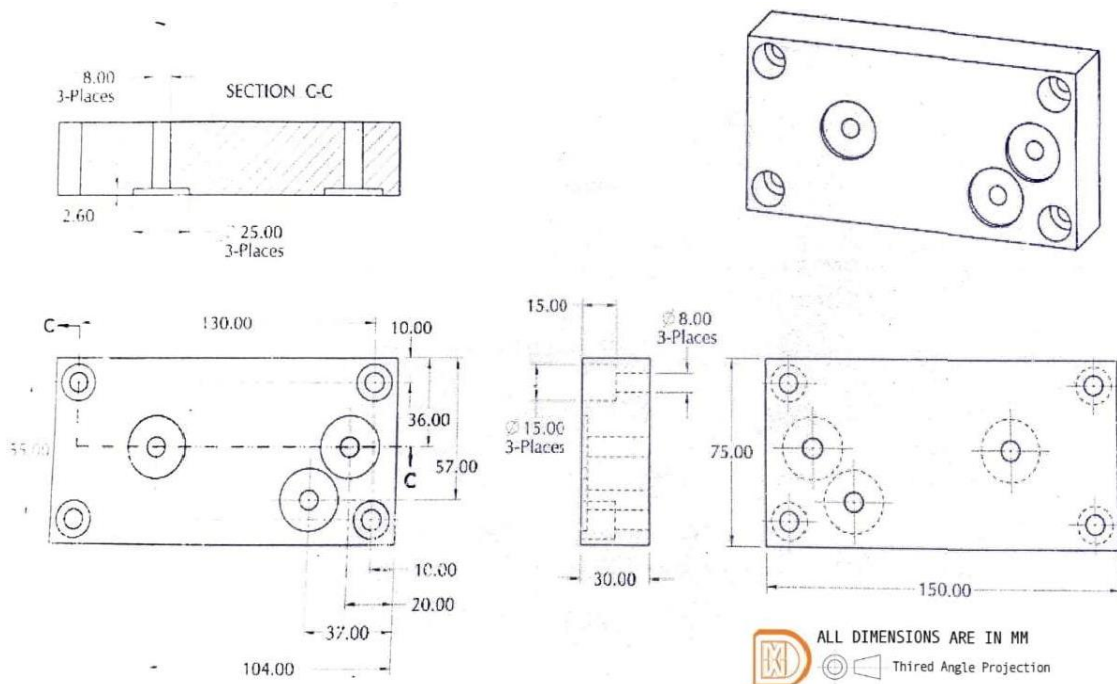

TASK:

1. Production drawing reading
2. Program writing
3. Simulation and analysis
4. Selection of tools and work holding devices
5. Machined component inspection

7) PART NAME - SOLENOID CAP

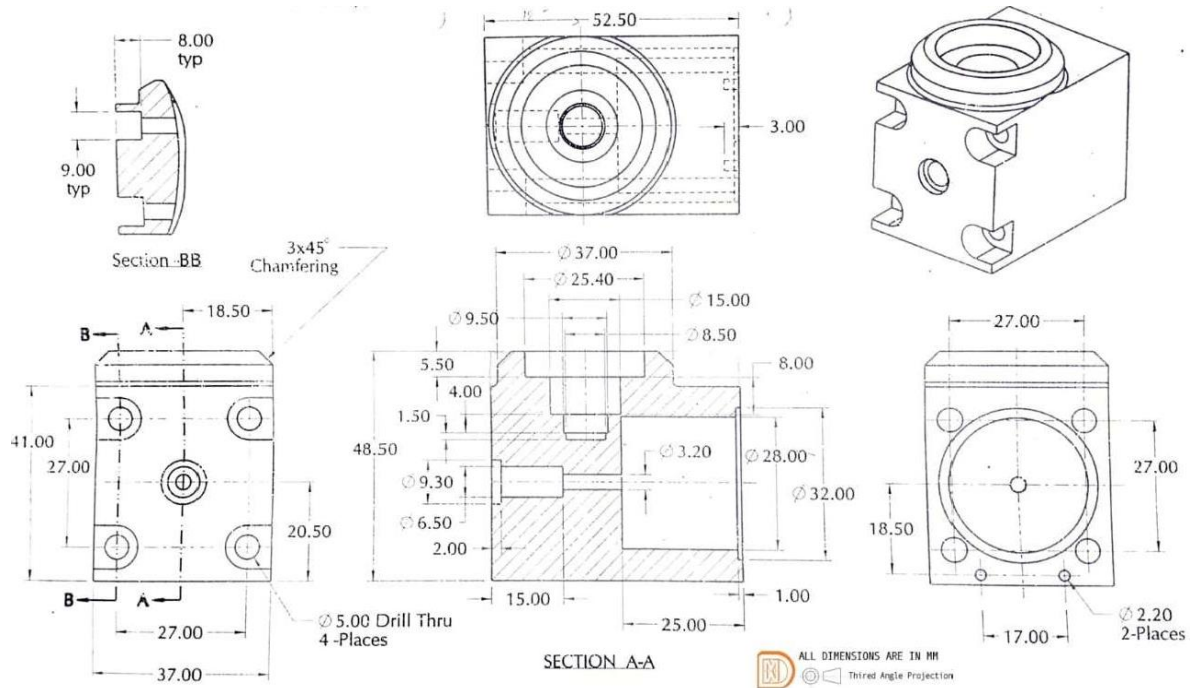

TASK:

1. Production drawing reading
2. Program writing
3. Simulation and analysis
4. Selection of tools and work holding devices
5. Machined component inspection

8) PART NAME - BODY BULL

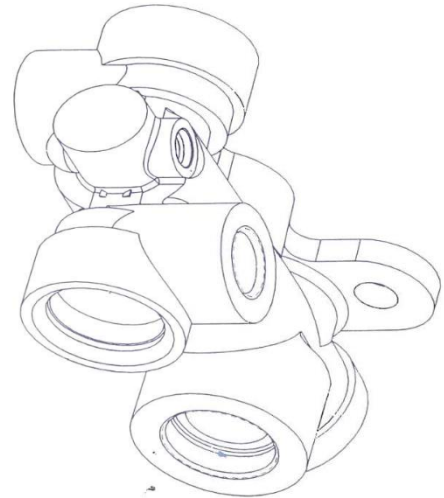
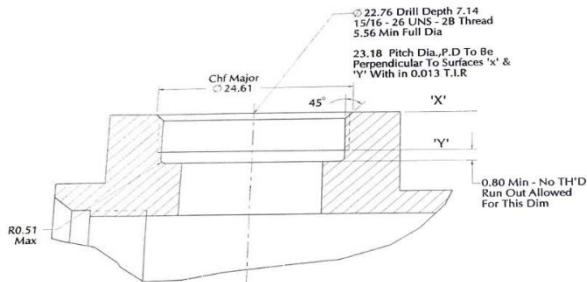
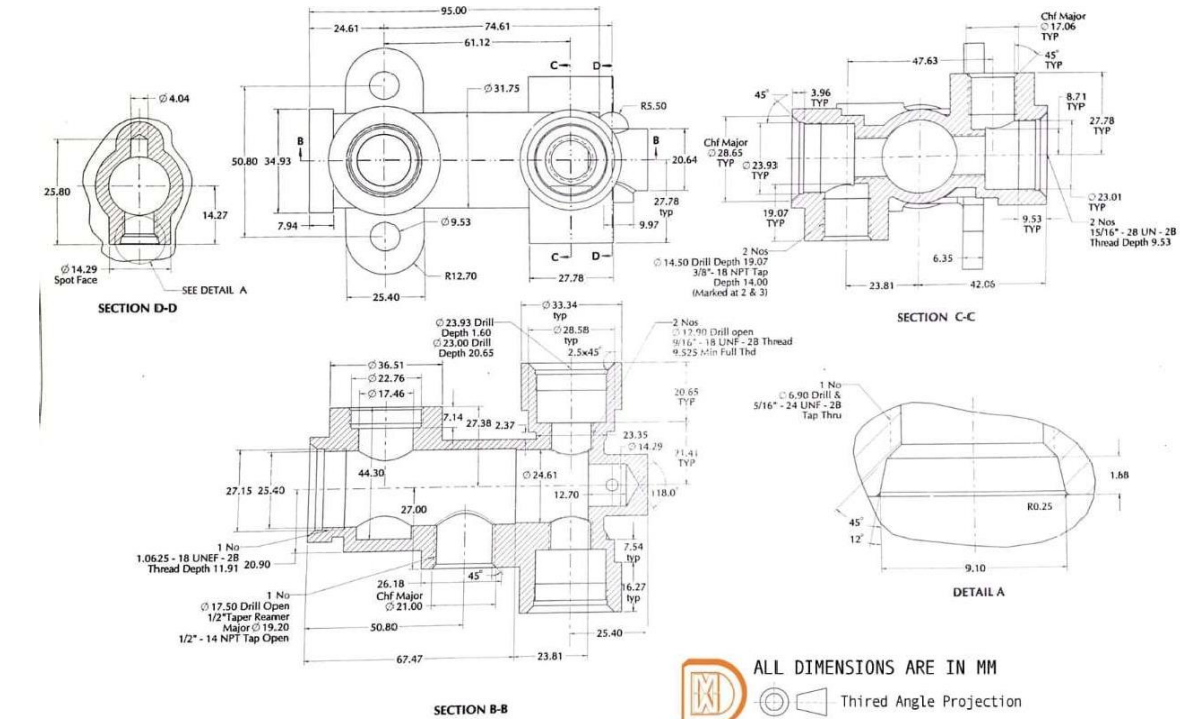

1. Production drawing reading
2. Program writing
3. Simulation and analysis
4. Selection of tools and work holding devices
5. Machined component inspection

9) PART NAME - SUPPORT

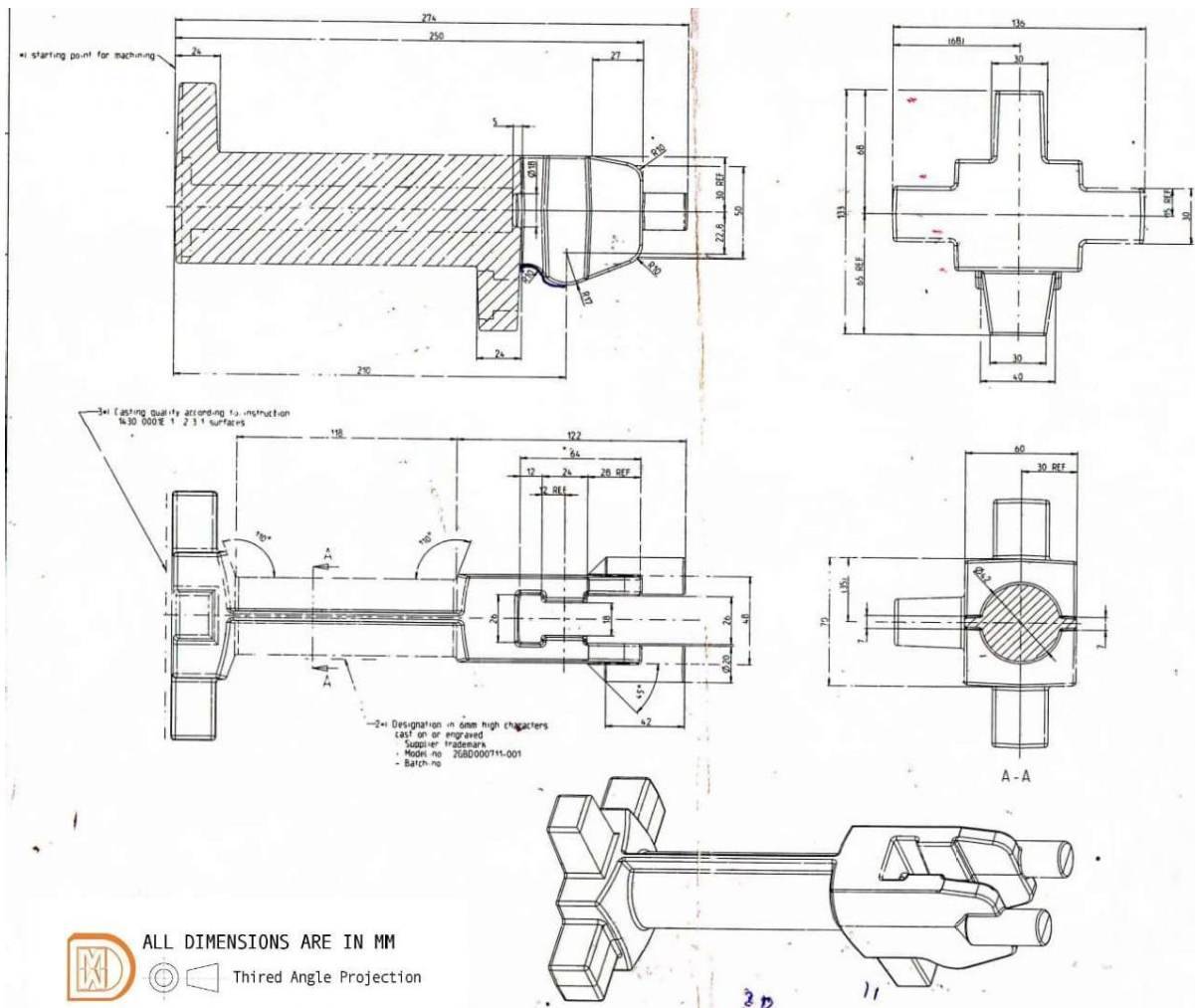

TASK:

1. Production drawing reading
2. Program writing
3. Simulation and analysis
4. Selection of tools and work holding devices
5. Machined component inspection

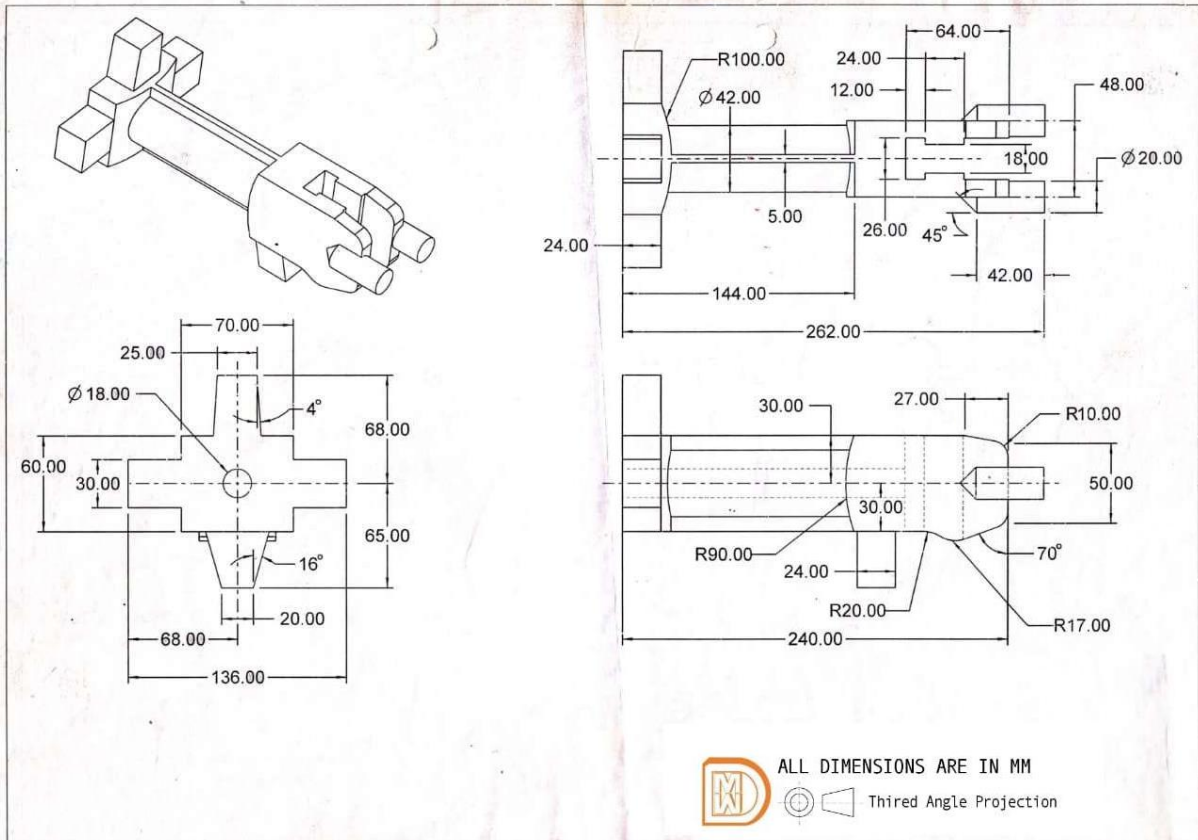

TASK:

1. Production drawing reading
2. Program writing
3. Simulation and analysis
4. Selection of tools and work holding devices
5. Machined component inspection

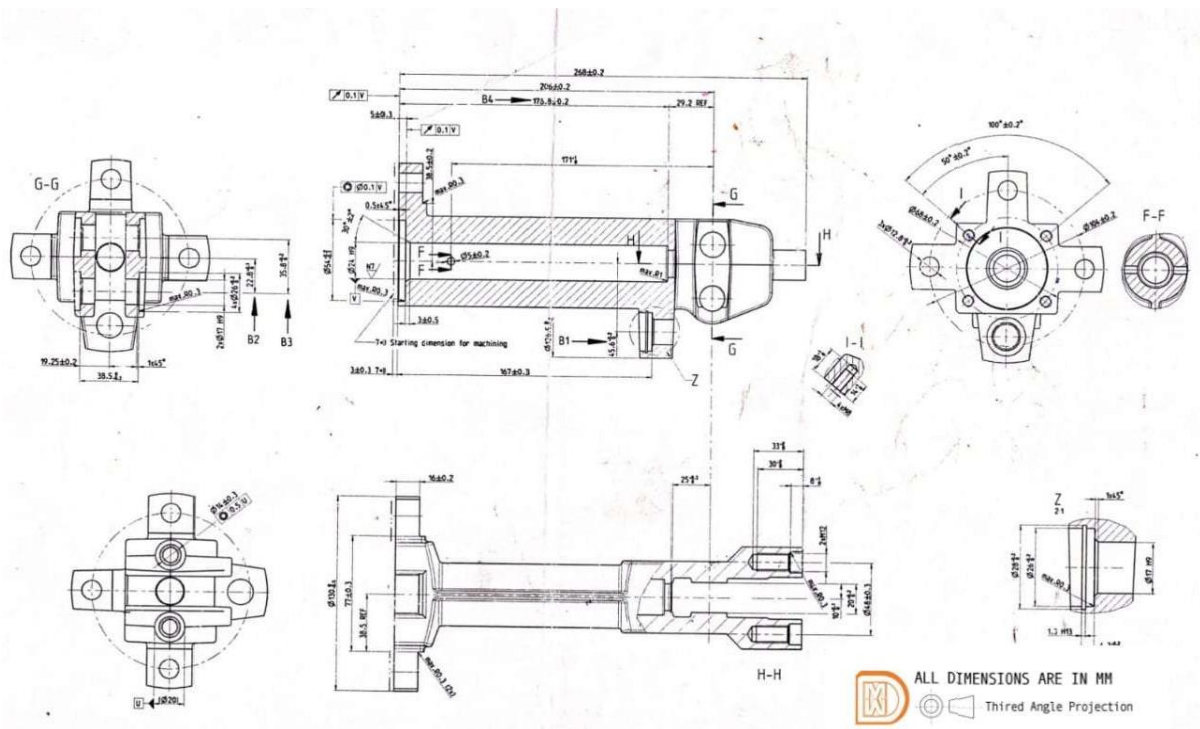

TASK:

1. Production drawing reading
2. Program writing
3. Simulation and analysis
4. Selection of tools and work holding devices
5. Machined component inspection

10) PART NAME - CRANK CASE

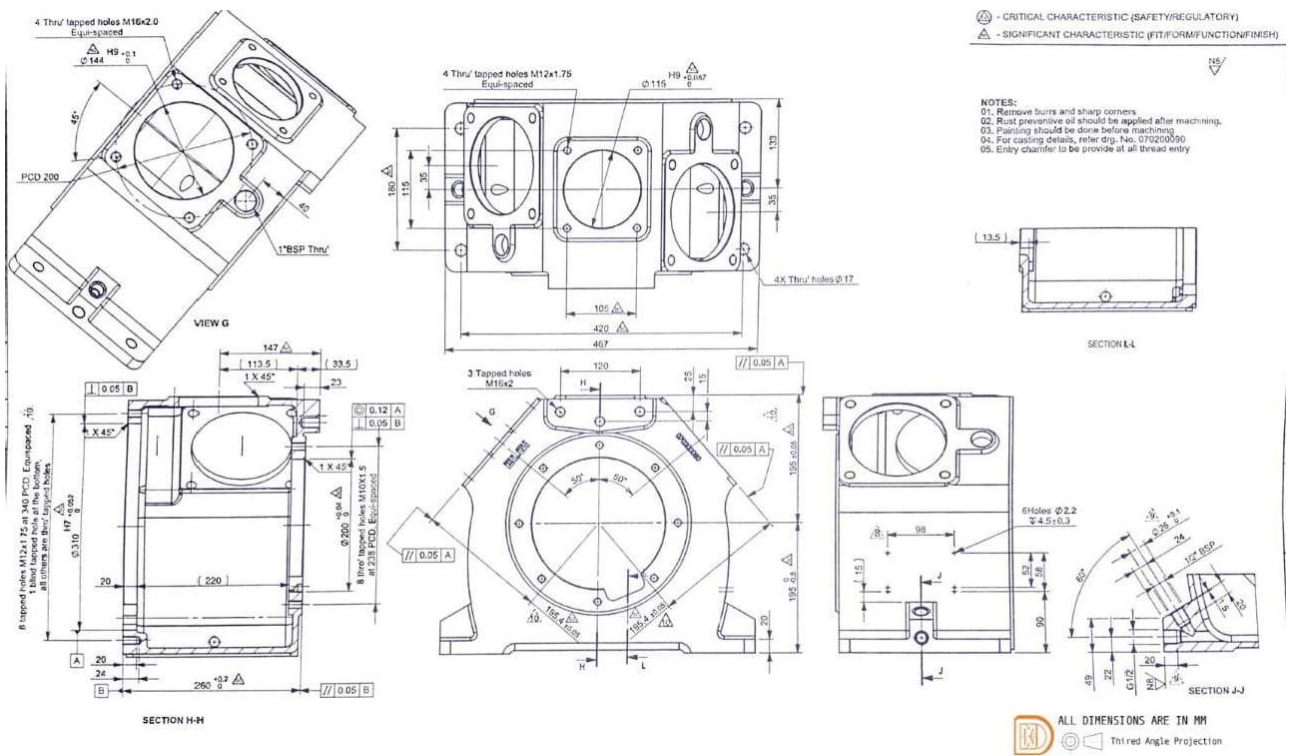

TASK:

1. Production drawing reading
2. Program writing
3. Simulation and analysis
4. Selection of tools and work holding devices
5. Machined component inspection

11) PART NAME - SQUARE GATE BONNET

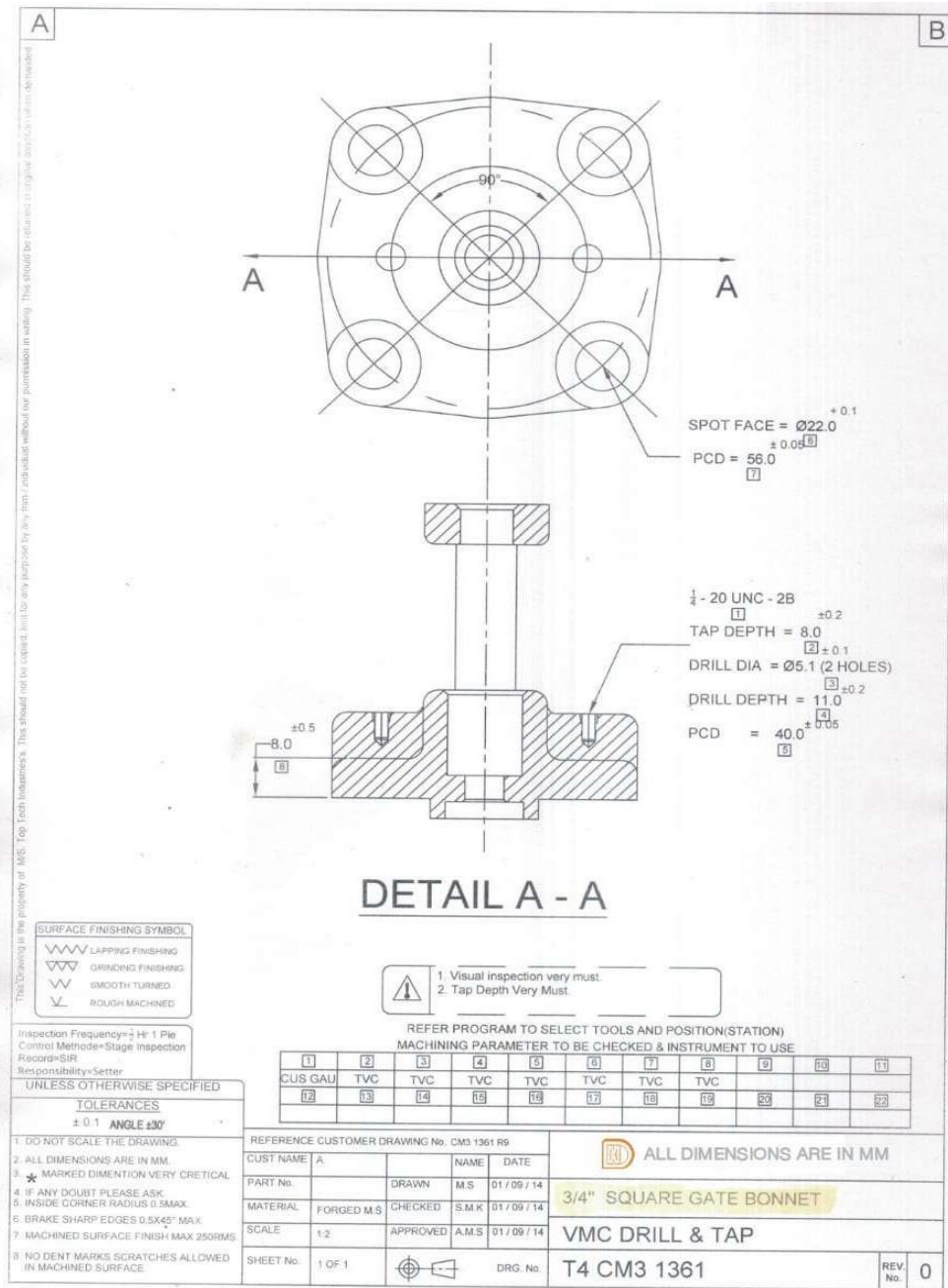

TASK:

1. Production drawing reading
2. Program writing
3. Simulation and analysis
4. Selection of tools and work holding devices
5. Machined component inspection

12) PART NAME - ROUND GLOBE BONNET

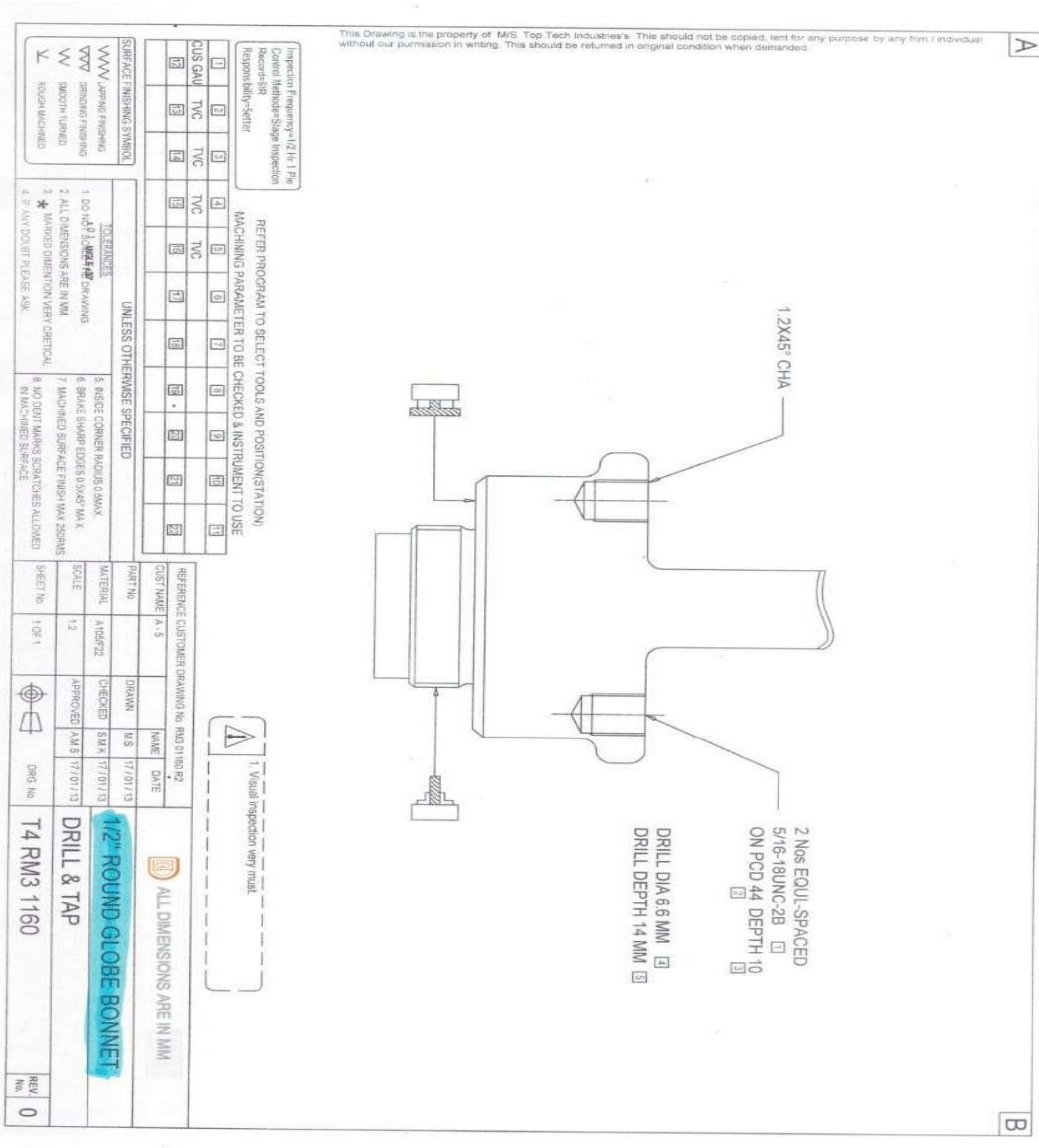

TASK:

1. Production drawing reading
2. Program writing
3. Simulation and analysis
4. Selection of tools and work holding devices
5. Machined component inspection

14) PART NAME - ROUND GATE BONNET

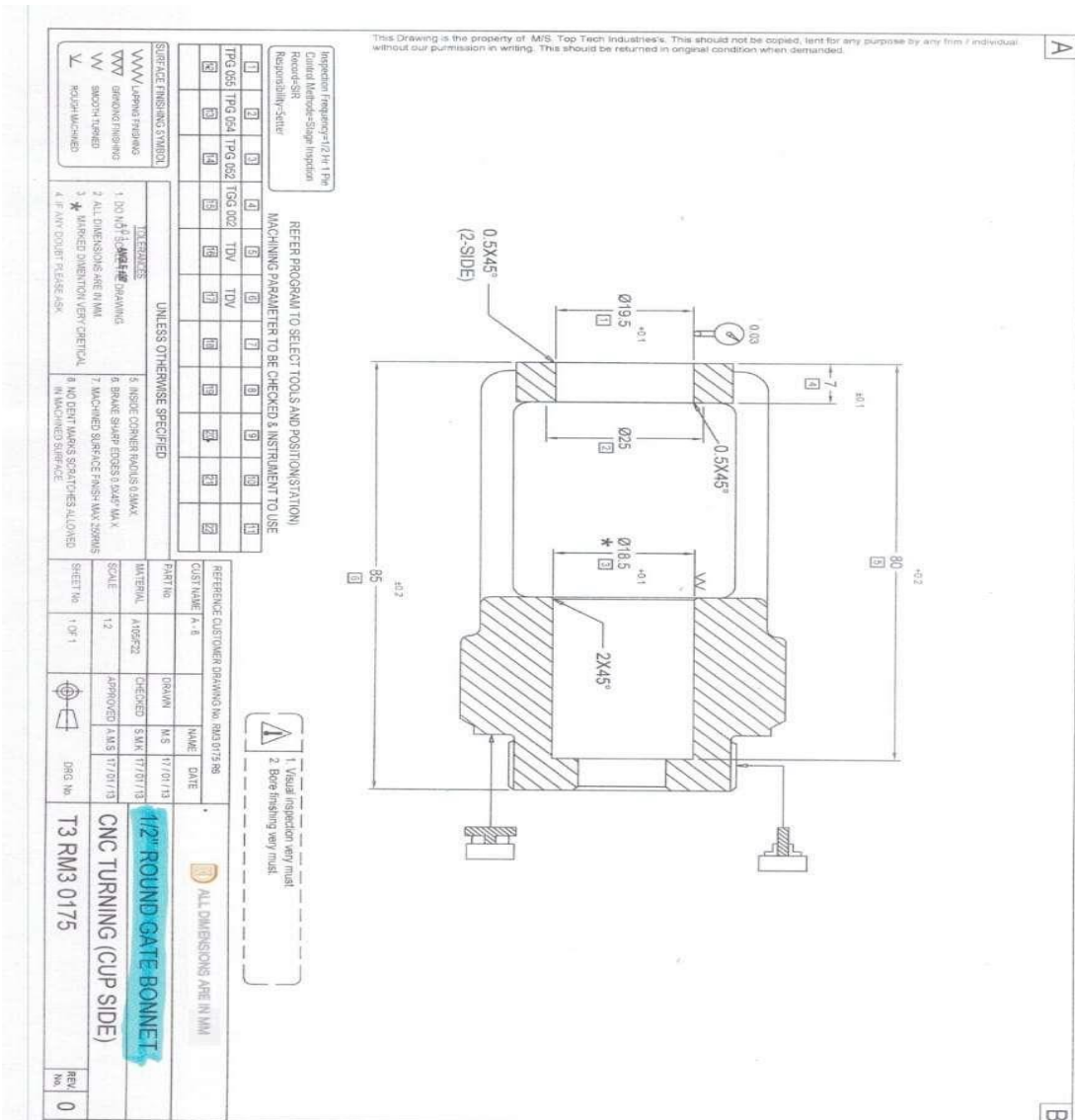

TASK:

1. Production drawing reading
2. Program writing
3. Simulation and analysis
4. Selection of tools and work holding devices
5. Machined component inspection

15) PART NAME –ROUND GLOBE BONNET

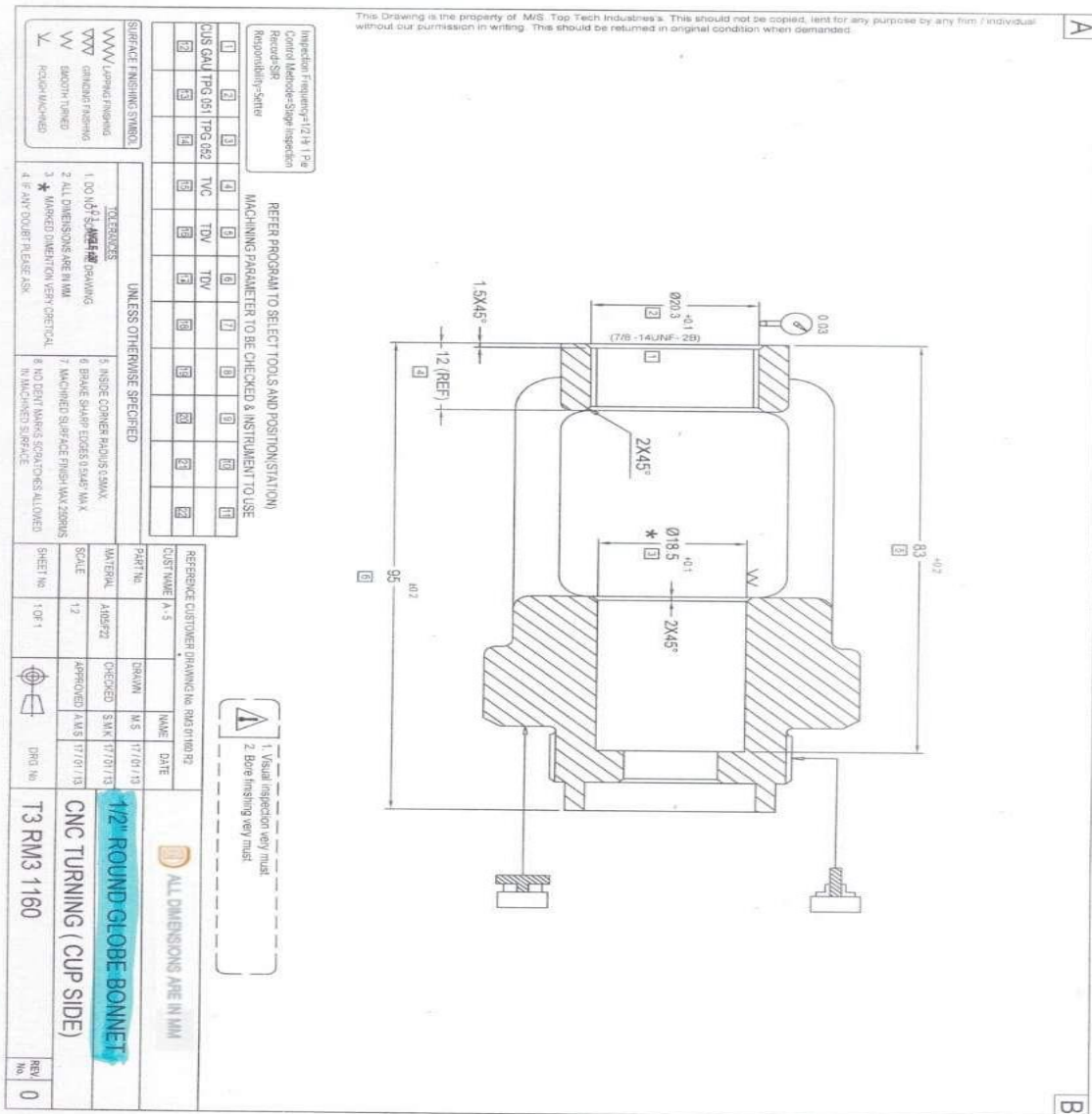

TASK:

1. Production drawing reading
2. Program writing
3. Simulation and analysis
4. Selection of tools and work holding devices
5. Machined component inspection

18) PART NAME - WHEEL HUB

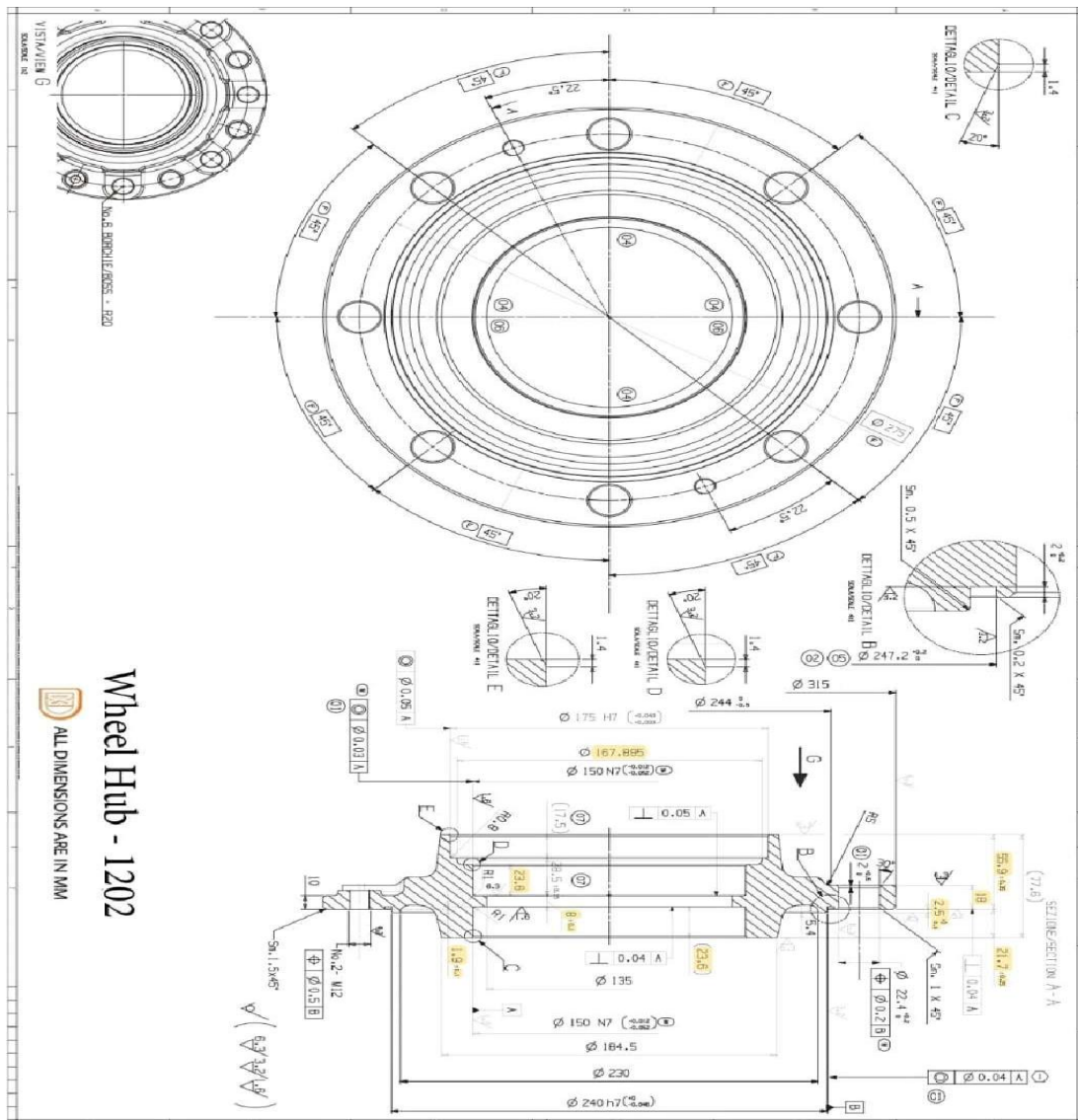

TASK:

1. Production drawing reading
2. Program writing
3. Simulation and analysis
4. Selection of tools and work holding devices
5. Machined component inspection

19) PART NAME - CARRIER HUB

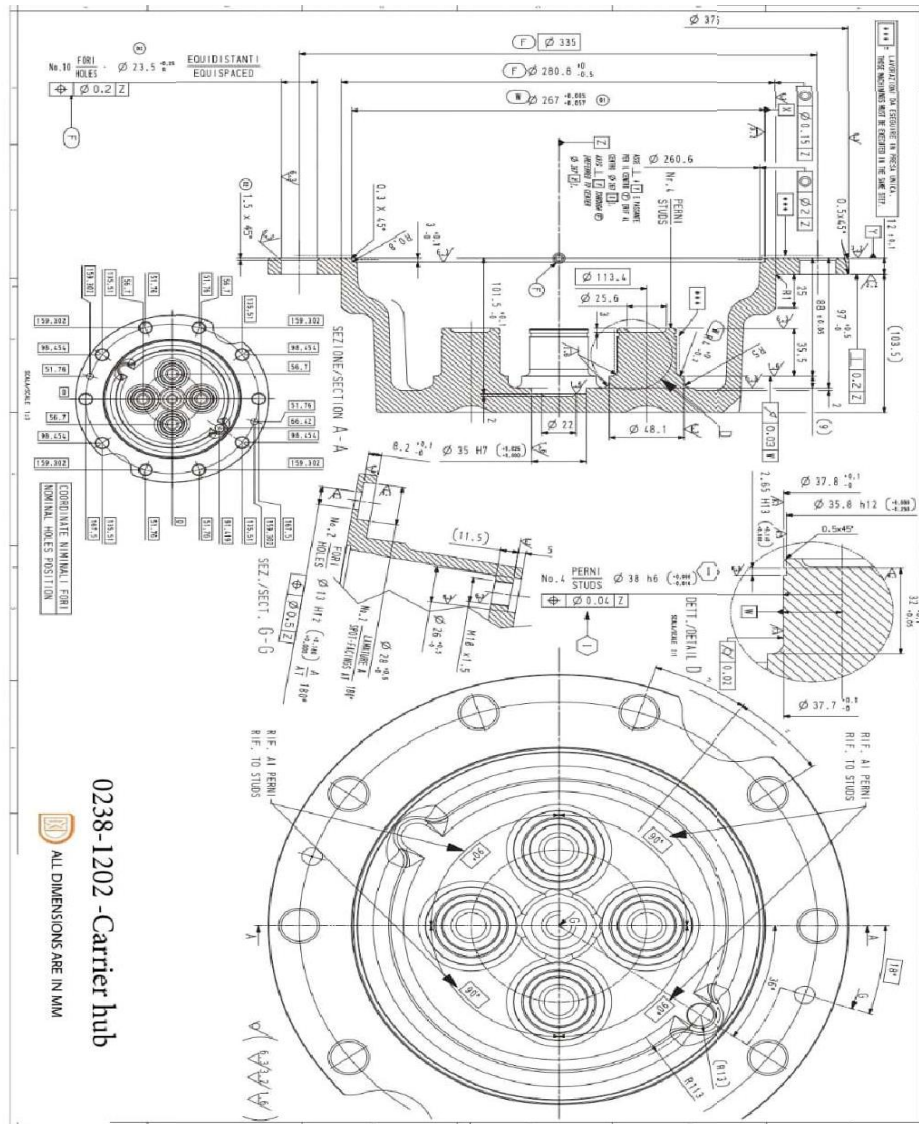

TASK:

1. Production drawing reading
2. Program writing
3. Simulation and analysis
4. Selection of tools and work holding devices
5. Machined component inspection

Student Assessment Plan:

Each of the above-mentioned test projects will be divided into tasks by the training partner for each specific institution. Such tasks will be jointly evaluated by the faculty and the training partner and the following weightage is to be followed.

- 70% weightage to the external practical assessment.
- 30% weightage to the internal assessment.

Final Test Project/External Assessment Plan:

The Final Test Project will be chosen from the list given above, jointly by the college faculty and the Training Partner. The Final Test Project will be assessed on the following tasks, for 70%

Details	Marks
Task: 1	20
Task: 2	20
Task: 3	20
Task: 4	20
Task: 5	20

Employment Potential:

This course shall enable mechanical, automobile and allied domain Engineers to get employment in sectors like Manufacturing, Assembly, Maintenance, Automotive industries, Electronics, aerospace industries and etc.